

CORIOLIS CONTROL

# InTech

with **Industrial** Computing®

# Extending the limits of Coriolis

By Uwe Hettrich and John Daly

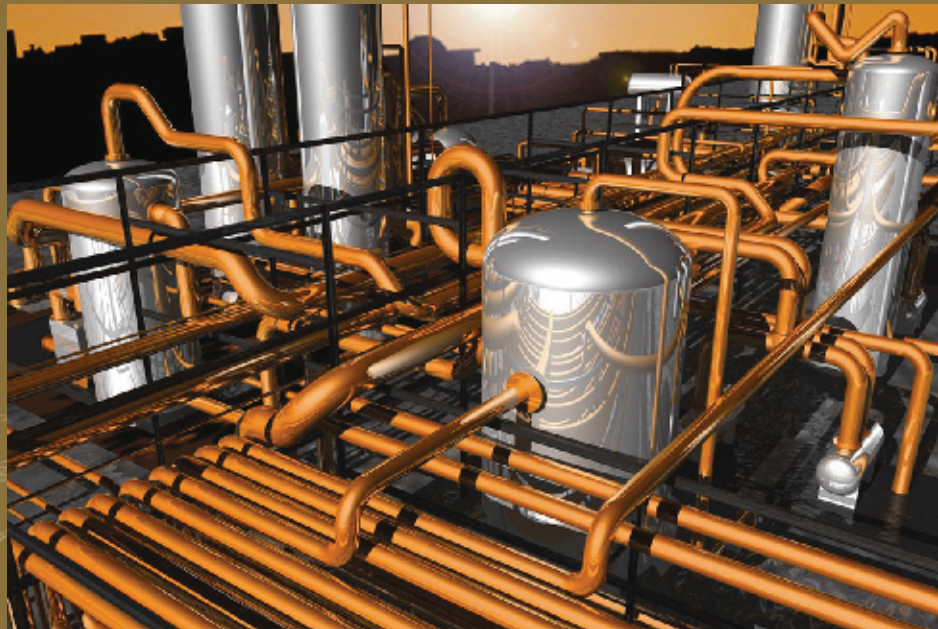

Source: Intergraph Corp.

Design brings high accuracy measurement to a wider range of applications.



South Fork Instruments, Inc.

3845 Buffalo Road

Auburn, CA 95602

Tel: (925) 461-5059

Email: [sales@southforkinstruments.com](mailto:sales@southforkinstruments.com)

The first commercially available flowmeter based upon the observed effects of mass flowing through vibrating tube systems appeared in the late seventies/early eighties.

The mass flowing through such tubes caused dampening and distortion effects in the tubing system, which correlated to the actual flow in the piping.

Today, many Coriolis mass flowmeters in use employ this technology, with about a dozen different manufacturers producing them. All of these meters build on a vibrating piping system with the inertia of the mass of material flowing through creating very small—but nowadays, easily measurable—deflections of the tubing.

The name for these meters comes from the force responsible for the deflections—the Coriolis force. Compared to other technologies, which mostly determine flow velocity, Coriolis mass flowmeters offer direct

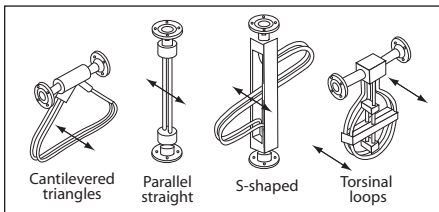

**Different shapes of Coriolis mass flowmeters**

mass flow measurement. Unlike velocity measurement techniques, changes in temperature, pressure, density, viscosity, and flow profile in general do not play a significant role when measuring flow with a Coriolis meter.

These tremendous advantages, along with a noninvasive nature, lack of moving parts (equating to high turn-down ratio and minimal maintenance), and high intrinsic accuracy (typically 0.15–0.5%) have made Coriolis meters very desirable as measuring elements over the past twenty years. Despite these features, the success of Coriolis mass flowmeters has not been great because of their high price compared to other meters' technologies. Over the last few years, prices have dropped due to designs oriented more to bulk manufacturing techniques and resulting economy of scale. Manufacturers have responded to the requirements of specific industries by offering dedicated solutions to applications such as natural gas dispensing, and this has led to further adoption of Coriolis meters in wider market areas.

Today we can find Coriolis mass flowmeters in nearly every industry, and users are benefiting from the low maintenance, high accuracy, and excellent stability that this technology brings.

### Excitation force applies

Coriolis mass flowmeters have different designs with regard to shaping the tube system for measuring the flow. The U shape was initially one of the most popular tube geometry designs, and it serves to illustrate the theory of Coriolis flowmeter functionality.

The principle of operation is this: Application of an excitation force to the U-shaped tubes causes them to oscillate backward and forward, while flow enters the tubes at one side of the meter, travels through the tubes, and exits at the other side.

The oscillation of the tubes is orthogonal to the material flowing within them. As material passes through the tubes, the flowing mass accelerates in the direction of the oscillation. Due to its inertia, the tubing sees a force—the Coriolis force—that adds to the deflection of the tube

around the oscillation axis. The tube form takes on a double-bended or "S" shape. This additional bending registers as a phase shift and is directly proportional to the mass passing through the tubes.

The additional bending, which is most pronounced in the middle of the U shape, is a direct result of Coriolis force and relates only to the mass moving through the meter. The more mass flow, the stronger the Coriolis force and the more pronounced the bending. The range of bending is very small, typically in the range of one ten-thousandth of a millimeter up to a few tenths of a millimeter, depending on design. For accurate, stable mass flow measurement, a good signal-to-noise ratio is necessary—high signal means significant bending and deformation of the tubes while low noise requires external factors like vibrations to contribute to the primary measured deformation. Both factors strongly relate to the design of a Coriolis flowmeter.

The design of a meter influences the strength of the induced Coriolis force by its geometric layout and the amplitude/frequency of oscillation. To achieve larger tube deformation and therefore more precision in measurement, fast and energetic swinging and a long "arm" (the distance from the upper U shape to the oscillation axis) is desirable. The momentum responsible for the deformation is proportional to these parameters. By contrast, working against the deformation by the Coriolis force is the elastic module of the tubes—here called the spring constant. The higher the spring constant, the less deformation that registers at a particular Coriolis force. Considering this, the design goals for a Coriolis flowmeter should not only consider the creation of a large Coriolis force, but also the spring constant of the tubes themselves as this can work against large deformations/deflections.

Considering these interdependencies, at first glance the ideal Coriolis mass flowmeter should have the following features:

- Long, easily bendable tubing systems
- Large distance between oscillation axis and excitation point
- Thin wall tubing to keep the spring constant small
- High energy excitation to create large oscillation amplitudes

Unfortunately, some practical aspects of meter design temper the design goals for the ideal meter:

- Long piping systems may create unacceptable pressure drop.
- High-pressure, abrasive, and/or corrosive media require thick wall tubing.
- High energy input may conflict with safety requirements in hazardous areas.
- Excessive excitation may lead to fatigue failure of the tubing.

The above, while strongly simplified, shows that there is no one ideal Coriolis mass flowmeter design. Regardless of where design emphasis lies, there will always be tradeoffs made for applicability and practical suitability against performance.

It is worth noting that the performance of a Coriolis flowmeter can suffer from external noise, and installation quality remains a key factor in Coriolis flowmeter performance. While installing the meter in a vibration-free environment can minimize external noise issues, the

design of the meter itself must be optimal to prevent problems. Here the criterion is to keep the system oscillation stable and difficult to disturb from the outside. It is important that balanced tubing is part of the hardware so that the swinging is very stable and possibly self-sustaining—like a tuning fork—and that the actual point of deformation measurement well decouples from the process.

Over time, the various designs have gotten better. The differences and limitations of these designs only become fully visible when exposing the meters to extreme applications and conditions. In these applications, the omega tube torsion Coriolis mass flowmeter design demonstrates distinct advantages over other designs.

### Particular design features of the omega tube meter

The omega tube torsion Coriolis mass flowmeter is unique in that it is equipped with torsion rods and crossbars. This design has proved to be universal, serving both “standard” mass flow applications and, more important, extreme applications with high flow rates, pressures, and/or temperatures:

- Rates up to 1500 mΔ/hour
- Pressures up to 900 bar (13,000 psi)
- Temperatures from  $-250^{\circ}\text{C}$  ( $-482^{\circ}\text{F}$ ) to  $400^{\circ}\text{C}$  ( $752^{\circ}\text{F}$ )

The omega tube design is somewhat different from traditional Coriolis meters. The active part of most mass flow-meters consists of a tubing system; the omega tube system consists of three different mechanical elements, with each dedicated to an essential function of the flowmeter:

*Half-circle measuring tube*—The Coriolis force deforms this part and it is therefore the active measurement element in the meter. Installed here are deformation sensors in the form of pick-up coils and magnets.

*Torsion bar oscillation system*—This system consists of two torsion rods and two crossbars providing the base oscillation system. It would oscillate even without tubing.

*Media feed tube section*—This section is below the mass bars and sees almost no bending from the meter oscillation; it sees only a low-stress torsion moment.

The separation of the functional elements gives the opportunity to optimize each element separately according to its function and mitigate the tradeoffs between the “ideal” design in the sense of creating strong measurable signal and application requirements, such as heavier wall thickness and wetted material selection.

The active measurement element is fixed left and right where it passes through the crossbar. Since the section is an exact semicircle, pressure changes—even the highest ones—do not alter its shape. Other shapes have a tendency to slightly lose their original form when pressurized and this affects accuracy. This means that a meter calibrated on water at low pressure, for example, can serve to measure compressed natural gas in the field at a pressure between 200 and 300 bar (2800 and 4200 psi) without affecting precision. Note that the active measurement section is very short and the use of a smaller diameter tube in this section (allowing more deflection/measurable effect) would only create a very moderate pressure loss due to its limited length.

External noise effects remain at a minimum because the measurement section is separate from the environment by the mass of the crossbar and, apart from

the pick-up devices that measure the deflection induced by the Coriolis force, the section is free of additional elements that could resonate and disturb the measurement.

The real key to the omega tube design flowmeter’s suitability to difficult applications is the unique oscillation system. The system’s characteristic components are the torsion rods and the crossbars. Each torsion rod with its crossbar represents an oscillation system on its own—it is a harmonic swinger like a tuning fork that works independently, even without attached tubing. The oscillation excitation energy is injected via coils sitting on the crossbars themselves. Being “independent” from the tubing, the oscillation system can be engineered without compromise and offers the advantages of large amplitudes of motion and stable and highly energized swing system.

The large amplitude generated is not critical in terms of mechanical stress to the tubing system. Unlike in a classical U-shape configuration, a large movement in the active section only results in small noncritical torsional movement in the media feed tube section and not in an “over-bending” of a tube. This feature makes it possible to use heavy wall thickness tubing while still allowing the generation of large amplitude oscillations.

The use of crossbars in conjunction with torsion rods acts as a spring creating very energetic and stable oscillation with little energy input. Once oscillating at harmonic frequency, the meter is very tolerant of disturbing and dampening effects because of the mass of the crossbars. A tubing system alone would not build up and keep this amount of oscillation energy. The energy requirement to sustain oscillation is so low that even full 6-inch piping with a wall thickness of over 5 mm can still be rated intrinsically safe for zone 0.

For most Coriolis mass flowmeters, the tubing actually represents the spring constant, and hence changes in the tubing directly influence the operation. Tubing in the omega tube design plays a secondary role with regard to

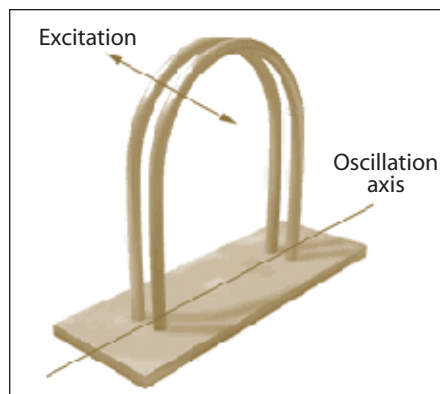

**Simplified U-shaped Coriolis mass flowmeter**

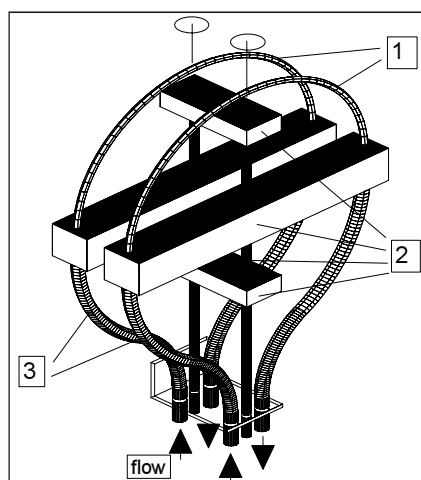

**Omega-shaped design with torsion rods and crossbar**



the spring constant of the meter and changes in the tubing type can easily be accommodated without major re-engineering, allowing the use of very different materials from standard stainless steel to exotic (with very different elasticity module) materials like Tantalum. Extreme diameter-to-wall thickness ratios are not a problem either. For instance, tubes with an outside diameter of 114 mm and a wall thickness of 11 mm work without degrading performance.

The torsion rods and crossbars also contribute to the reliability and safety of omega tube design meters. Even though the oscillation amplitudes at the end of the crossbars are large, stress on the actual meter tube is minimal, with only the media feed tube section seeing small torsional forces rather than intensive bending. Although omega tube mass flowmeters have been commercially available for seventeen years, there have yet to be any cases of tube failure due to fatigue in the media feed tube section. Meters using this design are very safe and suitable for hazardous applications.

### Omega tube applications

Omega tube Coriolis mass flowmeters have extended the use of Coriolis technology in meter size as well as pressure and temperature ratings. Following are a few examples where the omega tube meter has provided solutions for mass flow measurement applications that were not possible using other designs. Demand is increasing for high-pressure, large-line-size gas meters from the marketplace. These requirements are achievable using omega tube meters equipped and rated with ANSI 8-inch Class 1500 process connections. The next generation of meters will need to meet even more extreme limits.

*Shell Bitumen, 3-inch meter size, 363°C, 93 bar*—This project is typical of the type of application that can be solved with omega tube Coriolis meters. The requirement was to provide a high accuracy meter for a bitumen application that could reliably meet process pressure and temperature. The first meter went into service in 1993 and was on trial for a year. After this time, a detailed inspection for tubing failure took place. No indications of failure existed and other meters have since gone online. The meters are still in use with no failures to date.

Because of the thick wall tubing required for pressure rating, without the torsion rod/crossbar system, it would not have been possible to provide sufficient oscillation for meter operation. These meters actually consume less than 300mW and are intrinsically safe.

*Large volume fuel oil measurement with a 12-inch mass flowmeter*—Fuel oil is often highly viscous, with heating applied to make it “moveable” and custody transfer accuracy required at point of sale. Turbine and positive displacement meters are not ideal due to the abrasive characteristics of the oil. Ultra sonic flowmeters do not have the necessary accuracy.

*Extremely high-pressure Coriolis meter for hydrogen and other media*—Recently, the offshore industry and the automotive industry have shown increased interest in very high-pressure Coriolis meters—the offshore industry for measuring high pressure injection of corrosion inhibitors or similar, and the automotive industry for the dispensing of high-pressure H<sub>2</sub>. The H<sub>2</sub>

application is particularly extreme since pressures of 900 bar and turndowns of 1:100 are required, with the technical difficulty of the extremely low density of H<sub>2</sub>. Even at very high pressures, i.e., 500 bar, the density is only 40 grams/liter at ambient temperature. Even with the flexibility and advantages of the omega Coriolis flowmeter, the wall thickness of standard 316 stainless steel would be so great that a meter would not work to the required accuracy. It has been possible to use high tensile strength medical grade steel, and it is possible to build a meter with 8 mm diameter/1.6 mm wall thickness tubes that is rated to nearly 1000 bar. With this configuration, high accuracy measurements are possible from about 0.25 kg/min to 50 kg/min.

*High-volume hydrochloric acid measurement*—The highly corrosive nature of HCl has presented a challenge in terms of suitable material selection. Standard Coriolis flowmeters are usually stainless steel, a material unsuitable for HCl. Tantalum works in Coriolis flowmeters for smaller flow requirements, but few options are available for large-flow applications. Tantalum, when compared to stainless steel, is more ductile (more like lead) and consequently, using it as a substitute for stainless steel requires re-engineering of a standard tube Coriolis meter for which the spring constant is a critical parameter. The omega tube meter design lends itself to material changes of this nature relatively easily as the spring constant derives, for the most part, from the torsion rod/crossbar construction.

*Cryogenic, liquid H<sub>2</sub> at temperatures of -253°C* The omega tube meter design has also proven to be suitable for extremely low temperatures. The Munich airport liquid H<sub>2</sub> dispensing station is equipped with an omega tube Coriolis meter and has been in operation for about four years at temperatures not far above absolute zero.

### Take away differentiation

The omega tube Coriolis mass flowmeter design differentiates from others by its unique construction with torsion rods and crossbar.

With these design elements, the meters operate with large oscillation movements, thus providing measurement performance without putting undesirable bending stress on the tubing.

The design allows for the accommodation of special materials and thick wall tube without compromising performance.

Extreme applications with temperatures from -250°C up to 400°C and pressures up to 900 bar can operate using this technology as well as high volume/throughput requirements up to 1500 m<sup>3</sup>/hour.

### Behind the byline

**Uwe Hettrich** has a master's degree in electrical engineering and a business degree. He is the managing director of Rheonik Messgeräte GmbH in Odelzhausen, Germany. **John Daly** is a member of ISA, ASTM, and ISPE. He has a degree in combined studies and is the North American sales manager for Rheonik.

### Applications... Applications... Applications...

Coriolis mass flowmeters work in chemical, petroleum, petrochemical, pharmaceutical, food and beverage, and the pulp and paper industries. Because of their versatility, they can operate in process control, batching, inventory, precision filling of containers, and custody transfer.